

vega

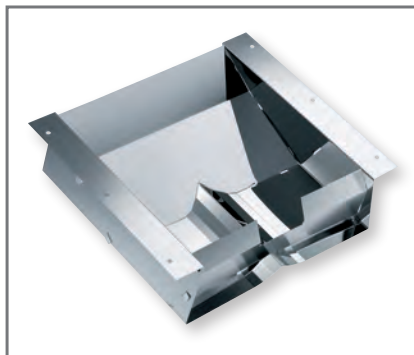

Lighting Applications



vega95 vega98



Internal lighting
Almecco offices in Milan



Daylighting system
Almecco offices in Milan



High efficiency T5 luminaire
with Vega reflector

Introduction Vega is Almecco's range of highly reflective aluminium with up to 98% or more total reflectance (DIN 5036-3 Integrating sphere). It is the result of a major technical development and investment project carried out by Almecco in 2006, which combines the proven quality of the bright anodizing processes and the latest technology of surface coating in vacuum. Key products in the Vega range are the reflector products Vega 95, with 95% reflectance, and the silver based Vega 98 with 98% reflectance.

Product structure The coating systems are applied to an electrochemically brightened high purity aluminium substrate coil, and start with an anodized base coat which gives a hard support to minimize abrasion damage. The strip is then treated under vacuum with specially developed processes to maximize coating adhesion and, depending on product type, is vacuum coated with a super pure reflection layer of either 99.99% pure aluminium (Vega 95) or 99.99% pure silver (Vega 98). These reflection layers are overlaid with a dual layer oxide system tuned for maximum visible reflection enhancement. This serves to increase the overall reflectivity provided by the metallic layers and adds protection against damage and degradation.

The Bernburg PVD line The new PVD (Physical Vapour Deposition) treatment line is located in Bernburg, Germany, close to one of the most important research & development hubs for vacuum coating of materials. The plant has been designed and equipped with the most recent systems for roll-to-roll metal surface treatment by PVD processes and profits from upgrading from Almecco's policy of continuous improvement and development of the product range.

Product advantages Vega products allow users to improve optical performance and optimize the luminous efficiency of lighting equipment by 10 – 20% for Vega 95 and even more for Vega 98. The most significant feature of Vega 98 is its extremely high total reflectivity, which can be over 99%. With such high performance, for every reflection from a luminaire surface less than 2% of the light is lost. This is typically 7 times less than what is lost by reflection from a typical pre-anodized surface or less than half what is lost from a 95% reflective product. Considering that in a multi-celled luminaire the light can be reflected more than four times before leaving the fixture, the benefits of Vega 98 can readily be imagined.

Product range The Vega 95 range covers almost all reflector surfaces and textures while the Vega 98 range comprises key finishes designed for high efficiency and aesthetic performance. Both are available in all suitable lighting industry formats and gauges.

Key characteristics Vega 95 – High total reflectance at all wavelengths from 400 to 700 nm giving excellent colour rendition, integrated hemispherical reflectance over 95% for most products. Absence of iridescence colours in the louvre

Vega 98 - High total reflectance at all wavelengths from 400 to 700 nm giving excellent colour rendition Minimum light loss even when there are multiple reflections in the louvre. Coatings applied using a special combination of deposition technologies that guarantee excellent adhesion of the layer system.

Vega 98 provides the ultimate in controlled high reflectivity, combining the proven quality of bright anodizing processes with the latest technology of surface coating in vacuum incorporating a pure silver reflection layer. Choosing from the Vega 98 range gives you the power to minimise energy wastage in your lighting projects.

Applications All Vega products

- Lighting – all applications requiring optimum energy efficiency, particularly high efficiency multi-celled parabolic luminaires and T5 fluorescent luminaires.
- Daylighting- reflective surfaces for light pipe construction- maximising light yield from every installation.
- Retrofit lighting – to bring old luminaires up to more modern efficiency standards.
- Greenhouse lighting – Almecco has a special quality "VegaGreen" for this usage.
- LED reflectors – helping to get the most from these energy efficient light sources

Vega 98 products

- Daylighting- reflective surfaces for light pipe construction- maximising light yield from every installation.
- Display screen illumination, profiting from the uniform spectral response of the material
- Specialist and very high efficiency lighting units – minimizing losses from multiple reflections in a louvre.
- Special projects - Almecco supports its customers in special developments, including pressed shapes, and would welcome enquires from clients on how to profit from variants of this high performance reflector sheet.

Display screen
illumination reflector



Vega Technical Data

Product	Type	Reflection Layer	Total Reflectance		Specular Reflectance		Diffuse Reflectance DIN 5036 - 3	Alloy	Temper (hardness)	Min Tensile Strength Mpa	Min Yield Strength Mpa	Min % Elongation A ₅ A ₁₀
			ASTM E 1651	DIN 5036-3	60° long	60° trans						

vega95

Vega 95100	specular	99.99% pure aluminium	>= 95	>= 95	90	89	< 11	1085	H18	125	105	2
Vega 95110	high specular	99.99% pure aluminium	>= 95	>= 95	91	91	< 6	1090	H18	125	105	2
Vega 95120	reflectormatt	99.99% pure aluminium	>= 94	>= 94	70 - 80	60 - 70	80 - 90	1090	H19	140	120	1
Vega 95125	lumenal matt	99.99% pure aluminium	>= 95	>= 95	81 - 84	81 - 84	60 - 70	1090	H18	125	105	2
Vega 95127	bright diffuse	99.99% pure aluminium	>= 93	>= 93	25	25	92	1090	H18	125	105	2
Vega 95138	mill finish	99.99% pure aluminium	>= 94	>= 94	65 - 80	25 - 45	85 - 92	1080	H18	125	105	2
Vega 95145	semi-specular	99.99% pure aluminium	>= 94	>= 94	70 - 82	70 - 82	40 - 55	5005	H16	165	145	2
Vega 95210	stucco	99.99% pure aluminium	>= 95**	>= 95**	not relevant		94	1085	H18	125	105	2
Vega 95220	small hammered	99.99% pure aluminium	>= 95**	>= 95**	not relevant		94	1085	H18	125	105	2
Vega 95230	hammered	99.99% pure aluminium	>= 95**	>= 95**	not relevant		94	1085	H18	125	105	2
Vega 95236	large hammered	99.99% pure aluminium	>= 95**	>= 95**	not relevant		94	1085	H18	125	105	2

vega98

Vega 98110	high specular	99.99% pure silver	>= 98	>= 98	93	93	< 7	1090	H18	125	105	2
Vega 98120	reflectormatt	99.99% pure silver	>= 97	>= 97	73 - 80	58 - 65	82 - 92	1090	H19	140	120	1
Vega 98125	lumenal matt	99.99% pure silver	>= 97	>= 97	83 - 87	83 - 87	63 - 73	1090	H18	125	105	2
Vega 98127	bright diffuse	99.99% pure silver	>= 97	>= 97	28	28	95	1090	H18	125	105	2
Vega 98210	stucco	99.99% pure silver	>= 98**	>= 98**	not relevant		95	1085	H18	125	105	2
Vega 98D80	specular diffuse	99.99% pure silver	>= 97	>= 97	47 - 53	46 - 52	75 - 82	1090	H19	140	120	1

**Measured on the flat surface before patterning

All information provided is based on up-to-date values where possible. Optical values are typical results from 0.4 mm metal and are published for guidance only; they may vary according to raw material thickness. For more detailed information please contact our technical sales department. Physical characteristics of the materials are in accordance with EN (European Committee for Standardization).

Applicable Standards

Specular Reflectance (ISO 7668)

Measurements are made with Dr. Lange REFO 3 D reflectometer

Total Reflectance (DIN 5036-3)

Measurements are made using a 50 cm integrating sphere (Ulbricht Globe)

Total Reflectance At 30° (ASTM E 1651)

Measurements are made with the Technidyne TR2 integrating sphere

Diffuse Reflectance (DIN 5036-3)

Measurements are made using our 50 cm integrating sphere with a specular exit port

European Standards (EN) For Aluminium Ente Nazionale Italiano Di Unificazione (UNI)

Alloys UNI-EN 573-3
Mechanical Properties UNI-EN 485-2
Measuring Standards UNI-EN 485-4

Test Standard For Anodic Oxidation

Microscopic measurement of Oxide Layer UNI EN ISO 1463

General Tolerance

Thickness tolerance: ± 0.03 mm
Width tolerance: ± 0.15 mm
Length-cut sheets: ± 1 mm/m

Note

All materials listed above can be delivered in various sizes and shapes according to customer requirements.

Products with protective tape are guaranteed for six months after delivery if stored in a conditioned room (temperature 20-30°C and relative humidity 50-60%) and kept away from sunlight and any heating source. Protective tape is not UV resistant.



Vega products are supplied with a peelable self-adhesive polyethylene protection tape, which guards against scratching during transportation and manufacturing.

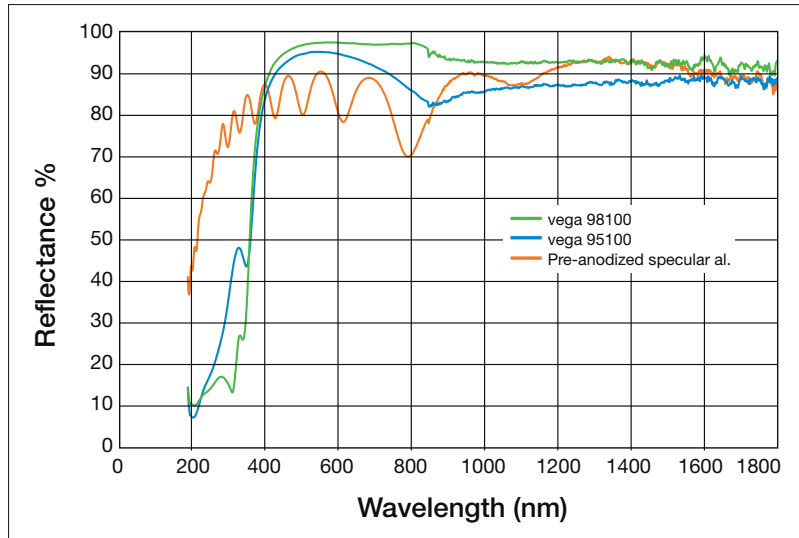

Comparison of spectral reflectance curves for Vega 98100 vs Vega 95100 and pre-anodized specular aluminium

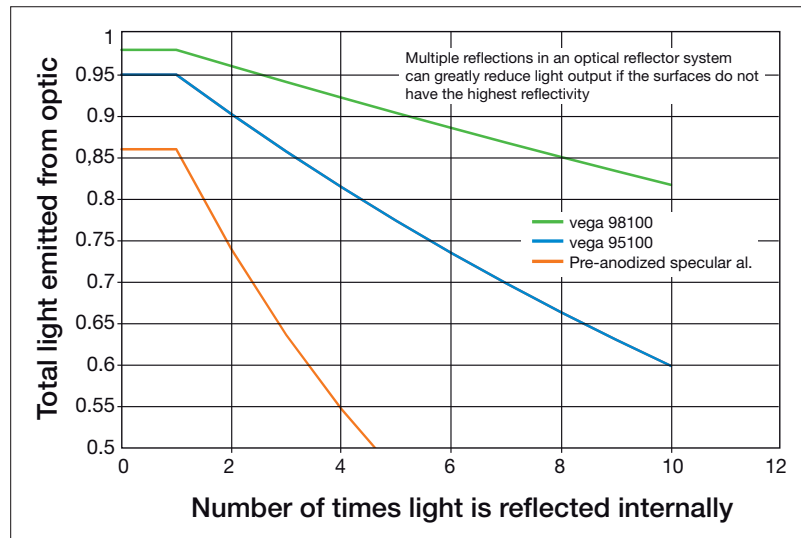

Graph showing reduction in light intensity with multiple reflections for 86%, 95% and 98% reflective materials

Coating System Diagram vega98

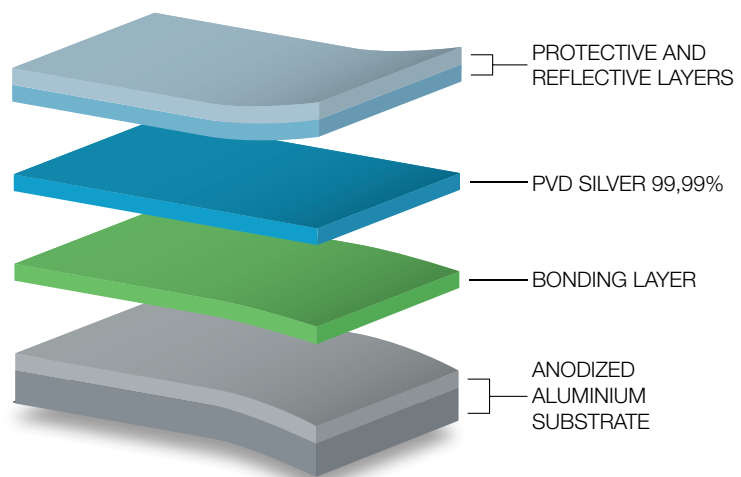



Milan, Italy - Bernburg, Germany - Munich, Germany
Goncelein, France - Atlanta, USA



Almecco Spa - Via della Liberazione, 15
20098 San Giuliano Milanese (MI) - Italy
Ph.: +39 02.988963.1 - Fax: +39 02.988963.99
info.it@almecogroup.com - www.almecogroup.com